

# ASSEMBLY INSTRUCTIONS

## Curve Display - Wood Tower

Part - 7206.002

DATE  
1/17/17

### Parts List

ITEM	PART NO	DESCRIPTION	QTY.
1	7206.001-10	Sign Channel	1
2	7206.001-11	Top Cap	1
3	7206.001-41-2	Metal Connector -Front	1
4	7206.001-41-1	Metal Connector - Back	3
5	7206.001-65R	Btm Right Panel	1
6	7206.001-66R	Top Right Panel	1
7	7206.001-67	Bottom Shelf Board	1
8	7206.001-40	Btm Shelf Bracket	4
9	DMD000182	Adhesive Glide Strip, 1 1/4" x 1/2" x 1/16" Thick, Off White	4
10	WL-RPH-8-916-B	Washer Lath Screw, Round Head Phillips Drive, #8 x 9/16", Black	8
11	7206.001-Dowel Pin	Dowel Pin	6
12	CS-BHK-1420-1-B	SCREW, CAP,BUTTON HEAD, HEX KEY DRIVE, 1/4-20x1", Black	24
13	NU-NS-1420-B	NUT, SERRATED FLANGE, 1/4-20, Black	30
14	CS-BHK-1420-12-B	SCREW, CAP,BUTTON HEAD, HEX KEY DRIVE, 1/4 X 1/2, BLACK	6
15	7206.001-66L	Top Right Panel	1
16	7206.001-65L	Btm Left Panel	1
17	HK-LA-532-R	Wrench: Hex Key, Long Arm, 5/32", Raw	1
18	7206.001-42-1	Top X-Brace	1
19	7206.001-42-2	Bottom X-Brace	2

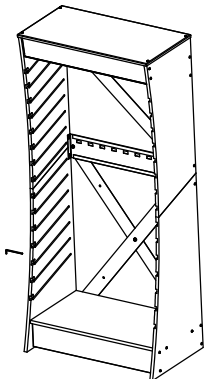
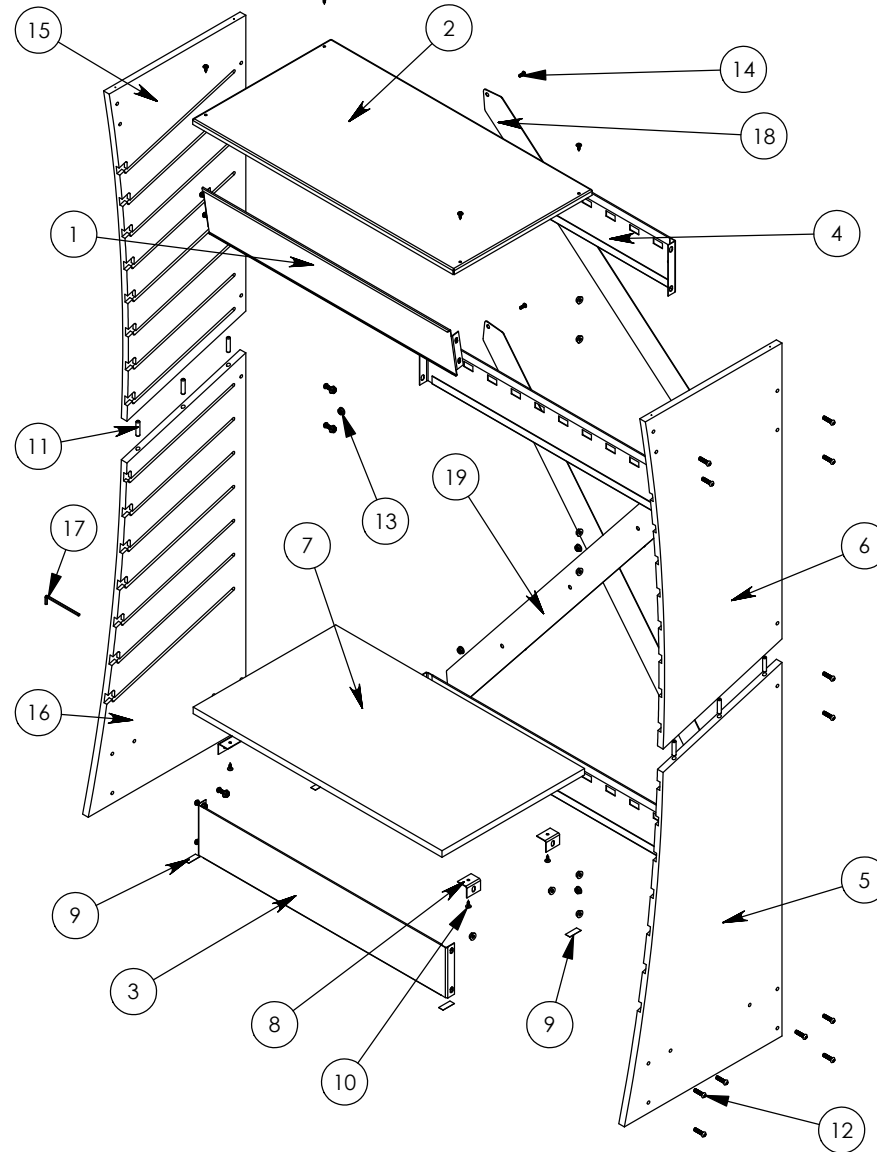

### Tools Required for Assembly

Phillips Head Screwdriver  
5/32" Hex Key (Supplied)  
7/16" Wrench

**A&E** Gütermann  
Consumer Division

# Curve Display - Wood Tower

Part Identifier

Sign Channel, 7206.001-10

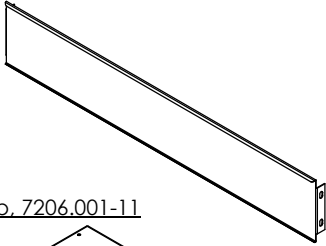

Top Cap, 7206.001-11

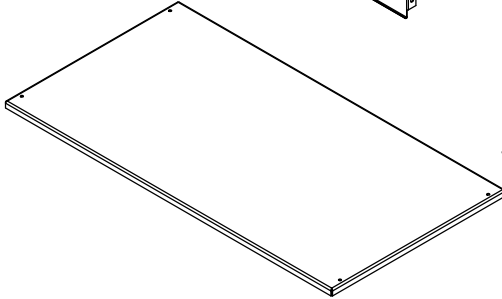

Top Left Panel, 7206.001-66L

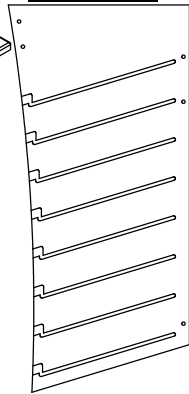

Top Right Panel, 7206.001-66R

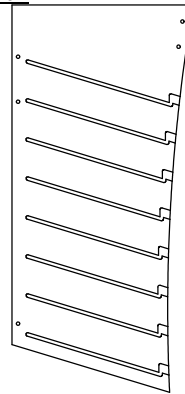

Back Metal Connector, 7206.001-41-1

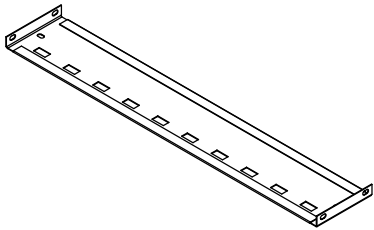

Bottom Left Panel, 7206.001-65L

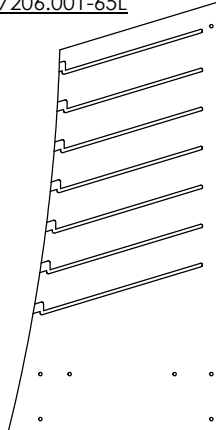

Bottom Right Panel, 7206.001-65R

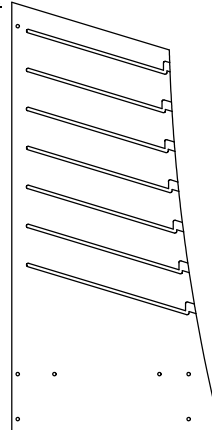

Back Metal Connector, 7206.001-41-2

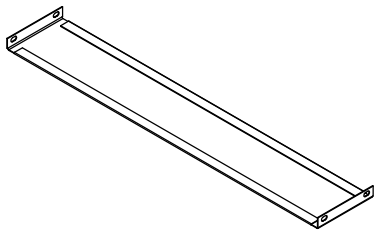

Bottom Shelf Board, 7206.002-67

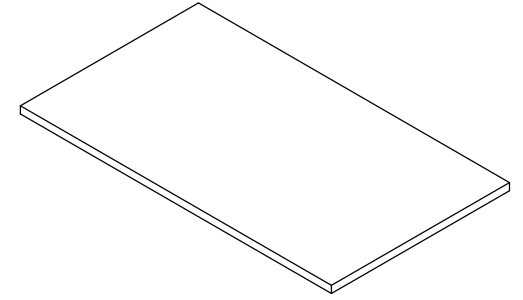

Dowel Pin, 7206.001-Dowel Pin



1/4-20 x 1 Button Head Screw, CS-BHK-1420-1-B

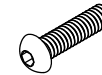

1/4-20 x 1/2 Button Head Screw, CS-BHK-1420-12-B



Washer, Lath Screw, Phillips WL-RPH-8-916-B



1/4-20 Serrated Flange Nut -Black, NU-NS-1420-B



Hex Key, 5/32" Long Arm HK-LA-532-R



Adhesive Glide Strip, DMD000182

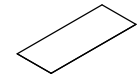

Top Brace, 7206.001-42-1



Bottom X-Brace, 7206.001-42-2

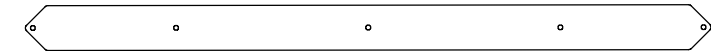

Bottom Shelf Bracket, 7206.001-40

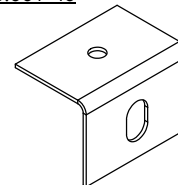

# ASSEMBLY INSTRUCTIONS

## Curve Display - Wood Tower

Part - 7206.002

DATE  
1/17/17

### Step 1 - Assemble the Lower Half of the Display.

-Attach Back Metal Connector to the Bottom Right and Left Panels using 1/4-20 x 1" button head screws and 1/4-20 serrated flange nuts as shown. Orient the slots Upward as shown.

-Attach Bottom Shelf Bracket to Bottom Shelf Board using #8 x 9/16" washer lath screws. Note: Bottom Shelf Board has pre-drilled holes on one side to accept the lath screws.

-Attach Bottom Shelf Board and Bottom Shelf Brackets to the Bottom Right and Left Panels using 1/4-20 x 1" button head screws and 1/4-20 serrated flange nuts.

-Attach Front Metal Connector (No holes on face) to the Bottom Right and Left Panels using 1/4-20 x 1" button head screws and 1/4-20 serrated flange nuts as shown.

-Attach Bottom X-Braces to the Back Metal Connectors using 1/4-20 x 1/2" button head screws and 1/4-20 serrated flange nuts. Also Connect X-Brace in center where they intersect with the same fasteners.

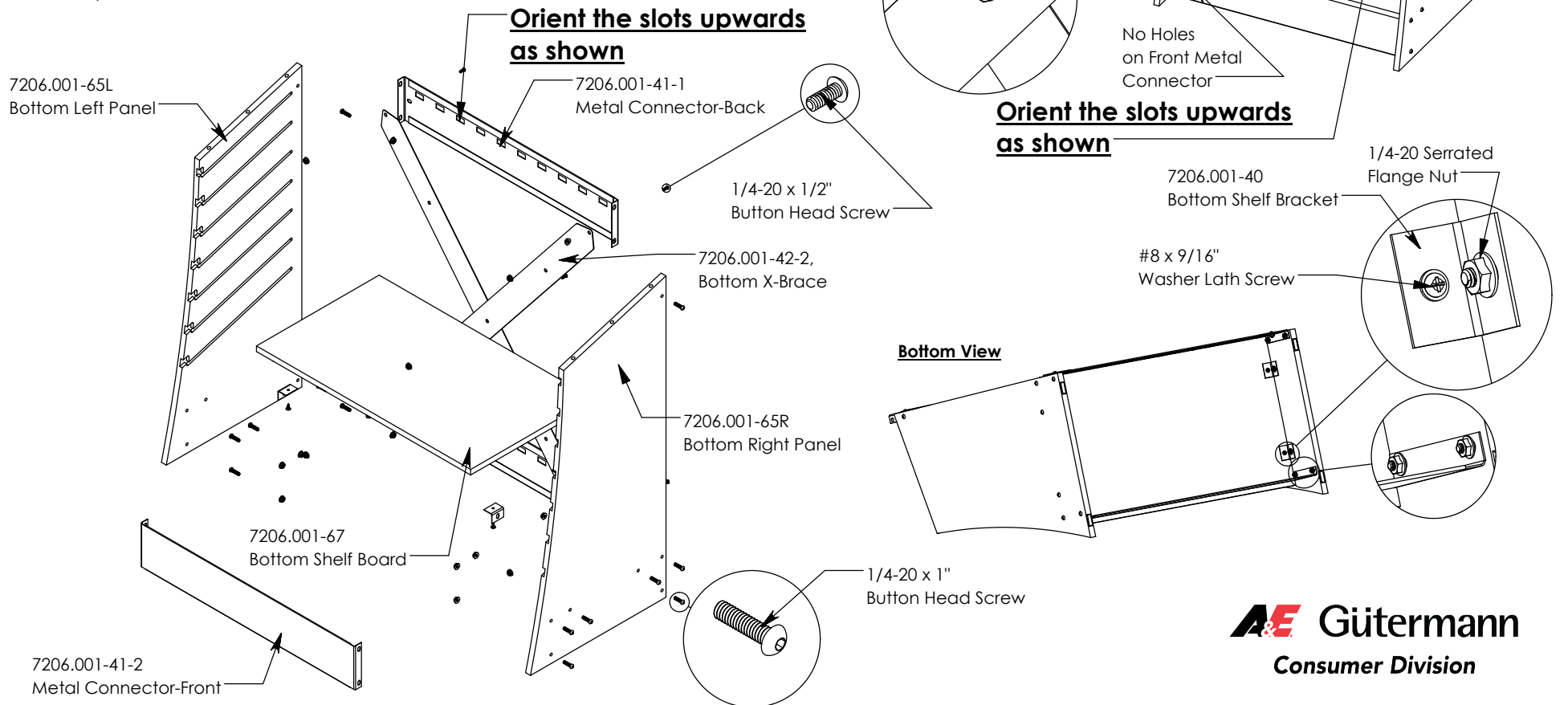

# Curve Display - Wood Tower

**Step 2** - Assemble the Top Half of the Display.

-Attach Back Metal Connector and Sign Channel to the Top Right and Left Panels using 1/4-20 x 1" button head screws and 1/4-20 serrated flange nuts as shown.

-Attach Top Cap to the tops of the Top Right and Left Panels using #8 x 9/16" Washer Lath Screws. Note: The top edges of the Top Right and Left Panels have pre-drilled holes to accept the lath screws.

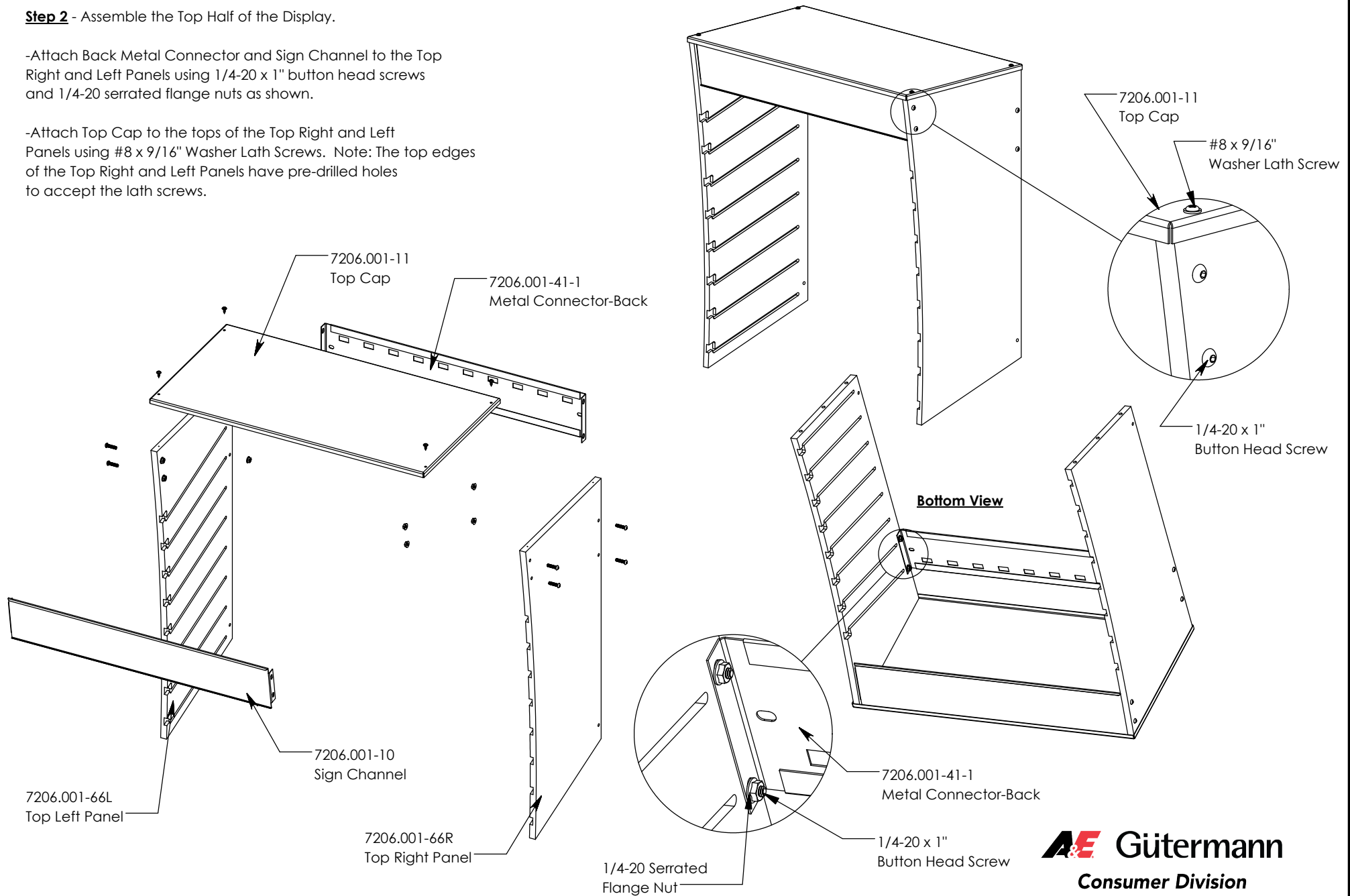

# Curve Display - Wood Tower

**Step 3** - Connect the Bottom Half to the Top Half.

-Insert Dowel Pins into the holes on the Bottom Right and Left Side Panels.

-Using two people, lift the Top Half up over the Bottom Half and drop it into place so that the dowel pins fall into the holes on the Top Right and Left Side Panels.

-Secure the remaining holes on the Back Metal Connector to the Top Half using 1/4-20 x 1" button head screws and 1/4-20 serrated flange nuts.

-Attach the Top Brace to the Metal Connectors using 1/4-20 x 1/2" button head screws and serrated flange nuts.

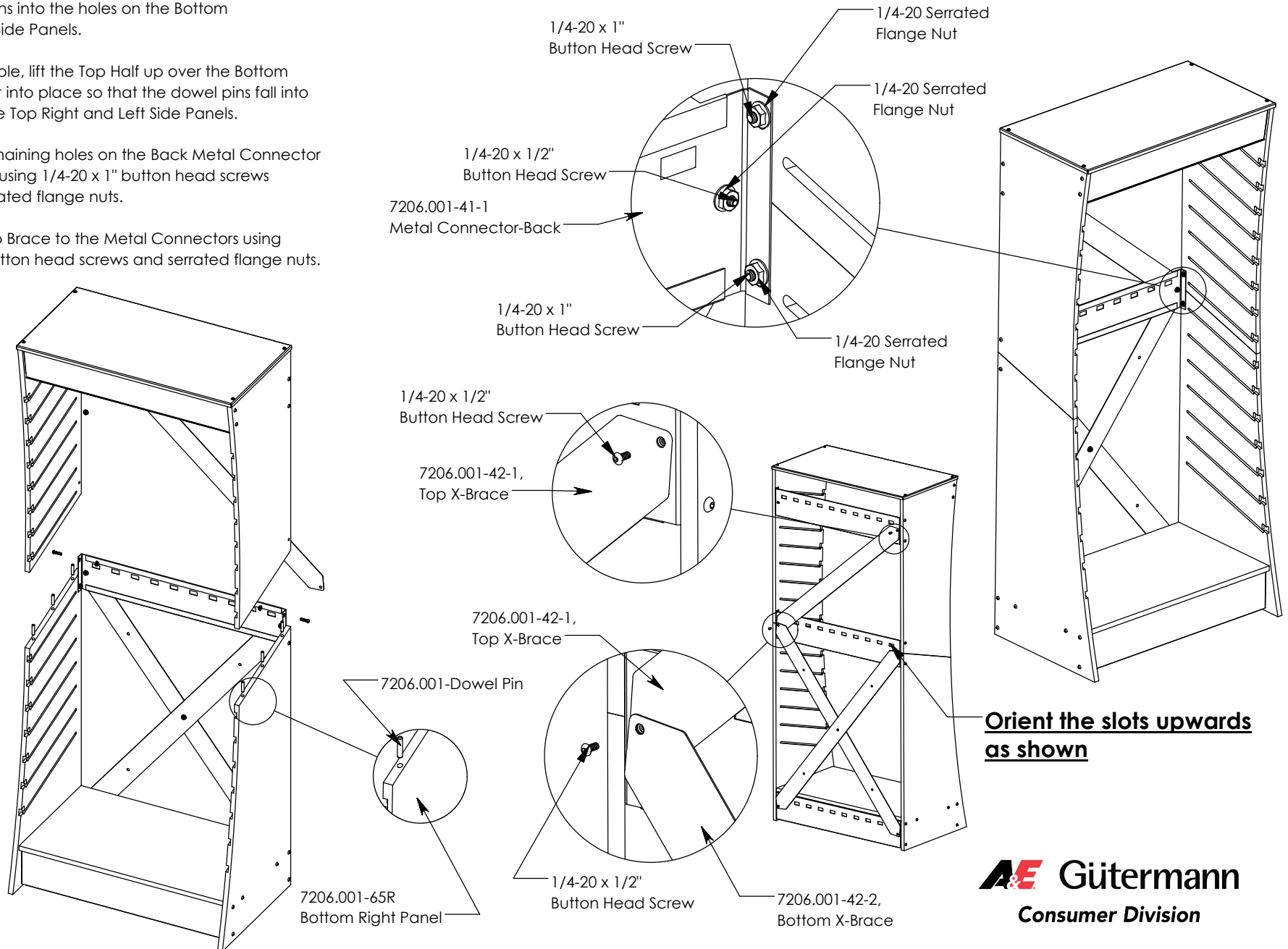

**Orient the slots upwards as shown**

**Step 4** - Install Graphics

Note: Graphics are not supplied with this kit.

-Install Sign into Sign Channel at the top of the display.

-Display is now ready to load with shelves.



# ASSEMBLY INSTRUCTIONS

## Maxi-Lock Shelf Kit

Part - 7206.003

DATE  
1/17/17

### Parts List

ITEM	PART NO	DESCRIPTION	QTY.
1	7206.001-51	Shelf Assembly	7
2	7206.001-52	Dump Bin Assembly	1
3	7206.001-53	Divider Assembly	2
4	CS-BHK-1420-12-B	SCREW, CAP,BUTTON HEAD, HEX KEY DRIVE, 1/4 X 1/2, BLACK	2
5	NU-NS-1420-B	NUT, SERRATED FLANGE, 1/4-20, Black	2
6	NS901	#NS901 - Non Skid Disk - 1"Ø	4

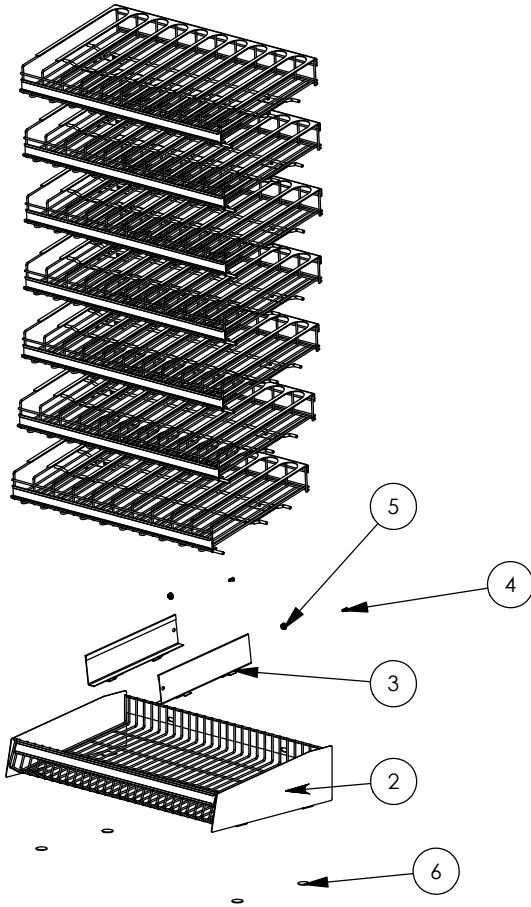

7206.001-52-Dump Bin Assembly

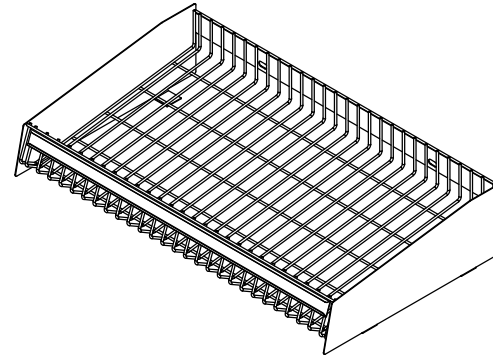

7206.001-51-Shelf Assembly

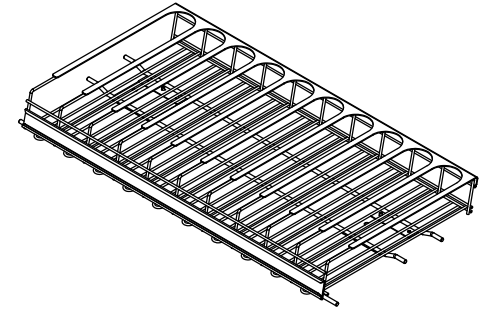

7206.001-53-Divider Assembly

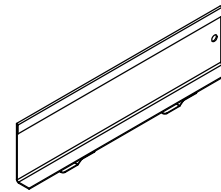

1/4-20 Serrated Flange Nut -Black,  
NU-NS-1420-B



1/4-20 x 1/2 Button Head Screw,  
CS-BHK-1420-12-B



NS901 - Non Skid Disk



### Tools Required for Assembly

5/32" Hex Key (Supplied with Wood Tower)  
7/16" Wrench

**A&E** Gütermann  
Consumer Division

# Maxi-Lock Shelf Kit

**Step 1** - Loosen the nuts on the middle connector bracket. This will allow the shelves to slide in more easily.

**Step 2** - Install price strip into the channel on the dump bin and then place the Dump Bin Assembly on the base of the wood tower. Secure Dump Bin to Cross Bracing using 1/4-20 x 1/2" Button Head Screws and 1/4-20 Serrated Flange Nuts as shown.

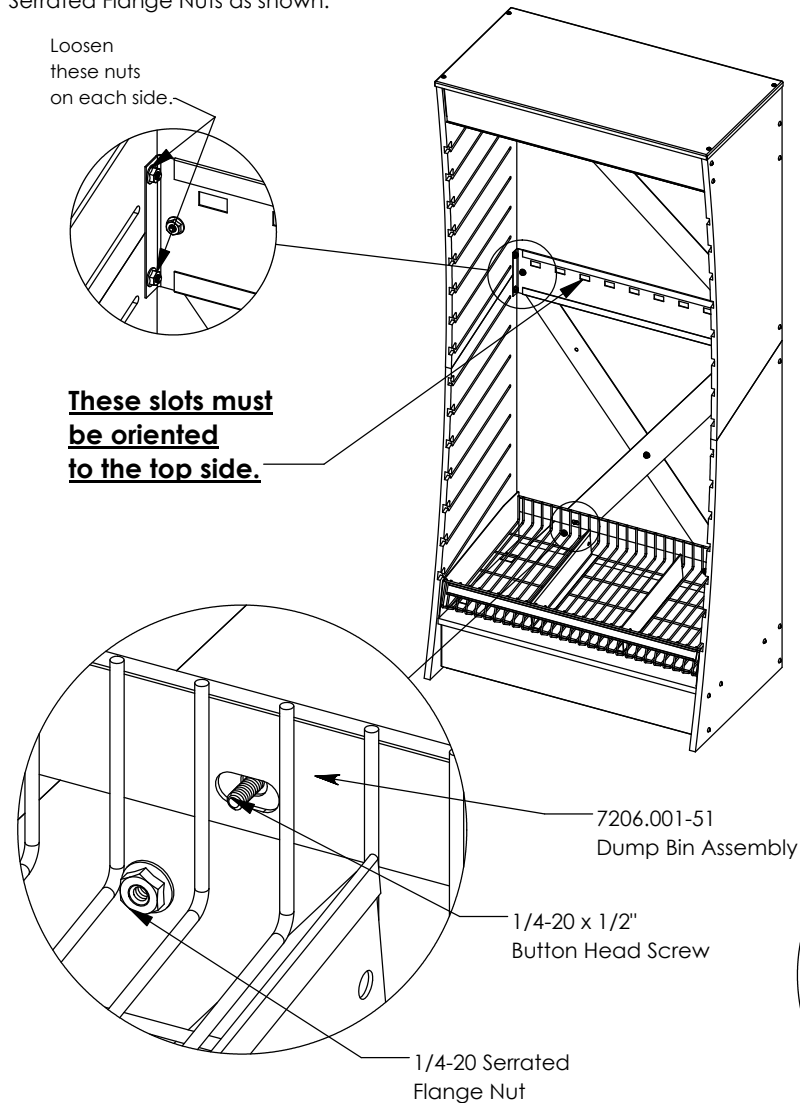

**Step 3** - Install Shelf Assembly into the grooved slots on the sides of each wood panel.

Start at the 2nd slot from the bottom and then install a shelf on every other slot. This is necessary for the Maxi-Lock Spools to fit.

After installing shelves. Re-tighten the nuts that were loosened on step 1.

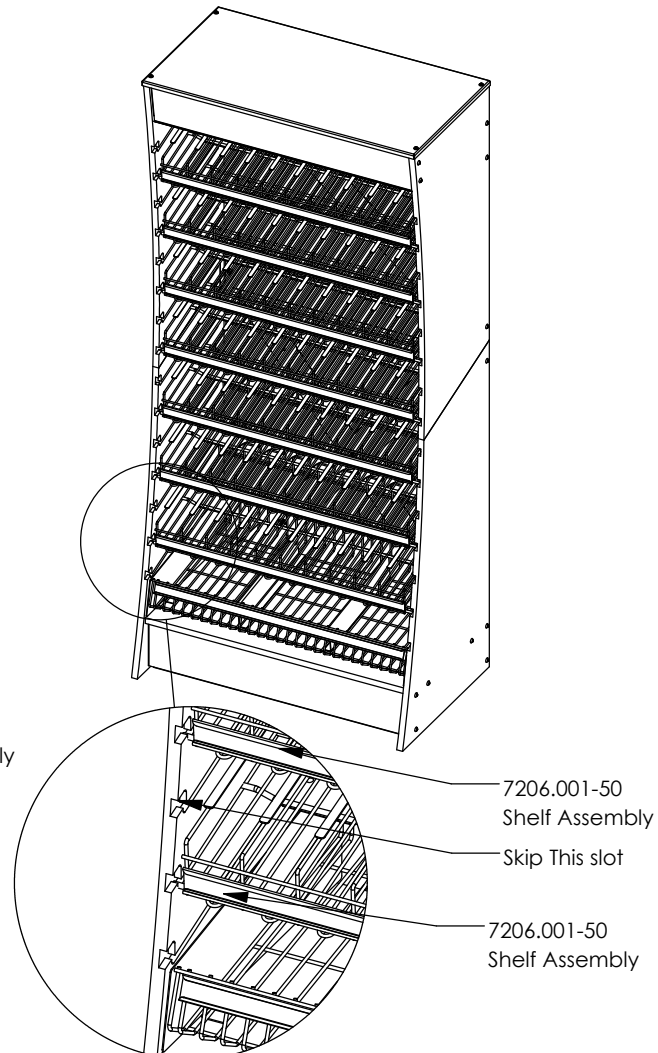

**Step 4** - Load with Product.

